



Replacement Parts Installation Instructions

Applies to Sun Dolphin, Sea Hawk and Play Mate brand pedal boats

Contents

Procedure	Description	Page
A)	HUB AND CRANK REPLACEMENT	2
B)	CRANK BUSHING REPLACEMENT	3
C)	PEDAL REPLACEMENT	4
D)	UNIVERSAL STEERING ROD REPLACEMENT	5
E)	RUDDER BRACKET / POST REPLACEMENT (1998 - CURRENT)	6
F)	RUDDER REPLACEMENT	6
G)	STEERING BUSHING REPLACEMENT	7
H)	TILLER STEERING HANDLE REPLACEMENT	8
I)	STEERING ELBOW REPLACEMENT	8
J)	CANOPY STRAP REPLACEMENT GUIDE	9



PROCEDURE A) HUB AND CRANK REPLACEMENT

- 1) Being able to lean the boat against a wall is helpful. Two people will also help.
- 2) Using two wrenches, remove the nylock nuts off the bolts from the under side of the boat where the hub and crank meet. There may be two bolts or four bolts depending the age of the boat.
 ►Note: You may need to use penetrating oil to help loosen the nut.
- 3) Once the nuts are removed tap the end of the bolt with a hammer to push it through and remove the bolts.
 If the bolt remains frozen you may have to use a punch.
- 4) From the deck side, pull on the crank to slide out of the hub. If cranks are difficult to remove use penetrating oil and thoroughly soak the area where the crank slides into the hub.
 Note: you may have to use force to get the parts to break free. This can be done by bracing the hub against the hull with a 2 x 4 and using a 2 x 4 and a hammer against the arm of the crank. See Figure 1.
If you cannot release the cranks from the hub due to corrosion your only option is to cut the cranks off. Cut cranks on hull side between bushing and hub tube. Do not cut the bushing. You will have to replace both cranks and the hub.
- 5) From the deck side, pull cranks out of bushing gently lifting crank upwards to remove past walls of footwell.
- 6) If replacing bushings - See **Procedure B**.
- 7) Remove any deposits on the crank using a scouring pad if they are not being replaced.
- 8) Using a Q-Tip and a jar of petroleum jelly, coat the end of the crank and the inside of the crank bushing. This will make assembly easier.
- 9) Slide both crank assemblies into bushings through the deck side. Install a spacer collar onto the crank.
 ►Note: You may or may not need the spacer collars. If you use the spacers, be sure to use one on each side.
- 10) Be sure the arms on the hub assembly are facing the back of the boat. While holding hub assembly in position, push the crank into the hub tube and repeat for other side.
- 11) There are two sets of bolt holes on each end of the hub tube, only the holes closest to the outside are used. Slide crank into hub tube so that the bolt holes line up and insert bolt through the holes with the socket head resting in the larger hole. Make sure crank single pedals are facing opposite directions before inserting the bolt. See Figure 1
- 12) Place nylock nuts on bolts and tighten.

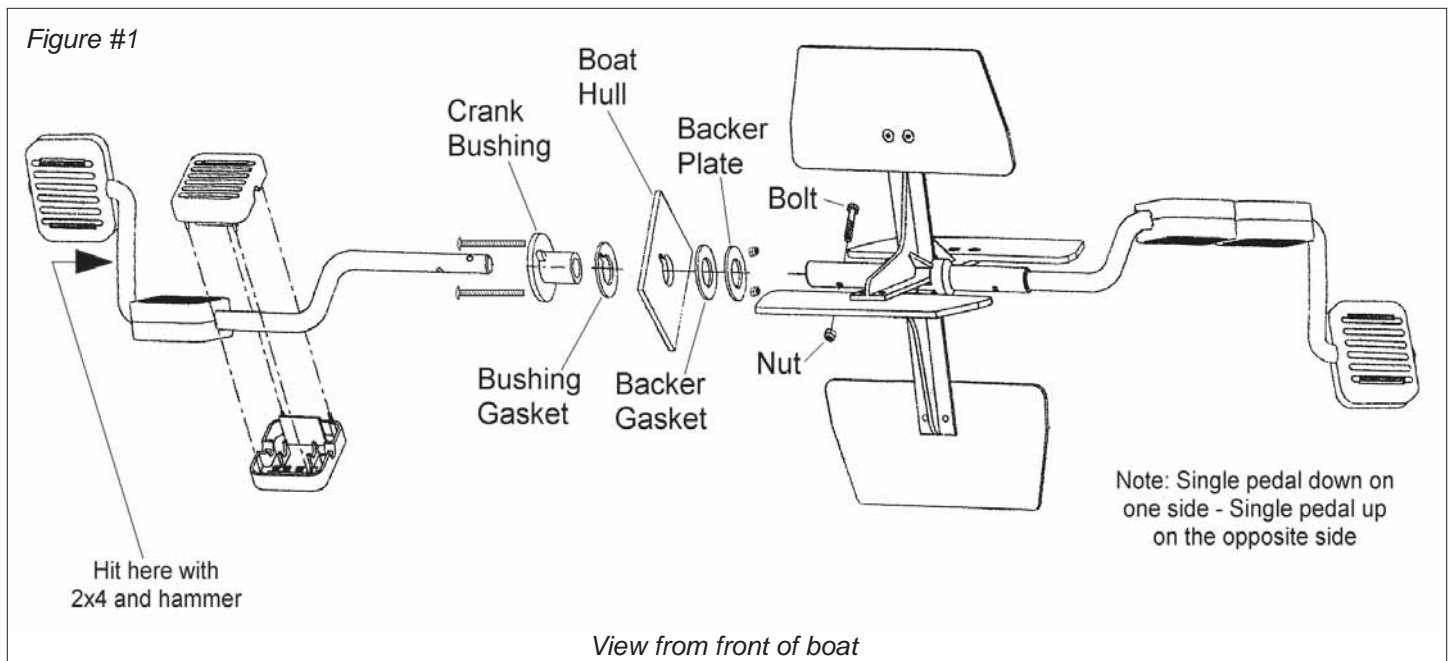



PROCEDURE B) CRANK BUSHING REPLACEMENT

- 1) Refer to **Procedure A** for removal of cranks and hub.
- 2) If your boat has a stainless steel retainer on the underneath side, cut or pry the retainer off using tin snips, needle nose pliers or a flat head screw driver cut or pry the stainless steel retainer from the under side of hull.
If your bushings are bolted in, remove the bolts. ▶Note: Be careful the stainless steel retainer is sharp.
- 3) Once retainer is removed slide off plastic backer plate and rubber gasket.
- 4) From the deck side, remove the old crank bushing or strike the bushing with hammer from the underneath side.

There are currently two different style replacement bushings, bolt-in and screw together.

For bolt-in replacement bushings:

- 5) Place one notched rubber gasket on the crank bushing if not already assembled to the crank bushing.
- 6) Place the new crank bushing in existing hole making sure that the tongue on the bushing lines up with the slot cut into the deck.
- 7) Using a #10 drill bit and the bushing as a guide, drill 3 holes through the deck and hull. Drill one hole then put screw through to hold bushing in place. Then drill the other two holes.
- 8) Place the # 10 x 1-3/4 bolts through the bushing and boat. Tap bolts through the drilled hole if needed.
- 9) Slide the Backer Plate Gasket on the bushing lining up the holes to the bolt pattern.
- 10) Slide the Plastic Backer Plate on lining up the holes with the bushing.
- 11) Assemble nylock nuts to the bolts and tighten. You may need a second person securing the screw from the top side.
- 12) Repeat for opposite side

For screw together replacement bushings:

- 13) Remove the adhesive backing paper from the gaskets and apply to bushing pieces one at a time, take care to align the small hole on the gasket.
- 14) Insert the threaded part in existing hole, orient the small alignment hole vertically upward. It may be necessary to drill a small hole in the boat using an "F" size drill bit using the alignment hole as a guide.
- 15) From inside the paddle wheel well, place the backing plate over the threads, ensure the pin engages the alignment hole in the bushing.
- 16) Thread the nut onto the bushing. Tighten the nut against the backing plate to a strong "hand-tight" torque. Ensure the backing plate is solidly in contact with the boat hull surface. Using channel locks, turn the nut 2-4 additional "clicks" of the locking feature. **Do not over tighten.** See Figure 3.
- 17) Repeat for opposite side
- 18) Refer to **Procedure A** for installation of cranks and hub.

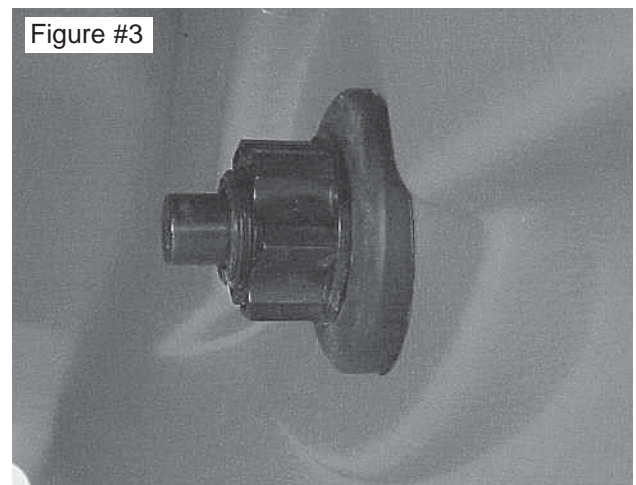
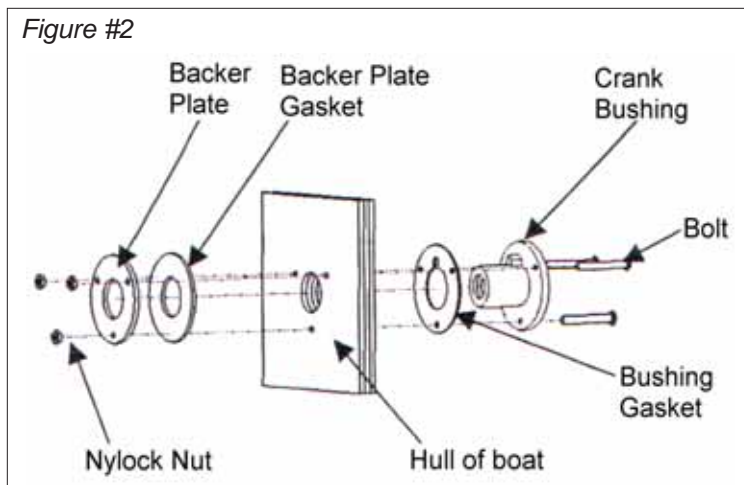



PROCEDURE C) PEDAL REPLACEMENT

- 1) The pedal assembly consists of (2) half pedals.
- 2) Remove old pedal if present.
- 3) Place 1/2 half of the pedal in the desire position, (see Figure #3)
- 4) Rotate the other half of the pedal 180 degrees
- 5) Place other half over the crank
- 6) Line up the locking tabs (Figure #4)
- 7) And press together
- 8) If pedal halves won't click shut use a little force till you hear a click sound.

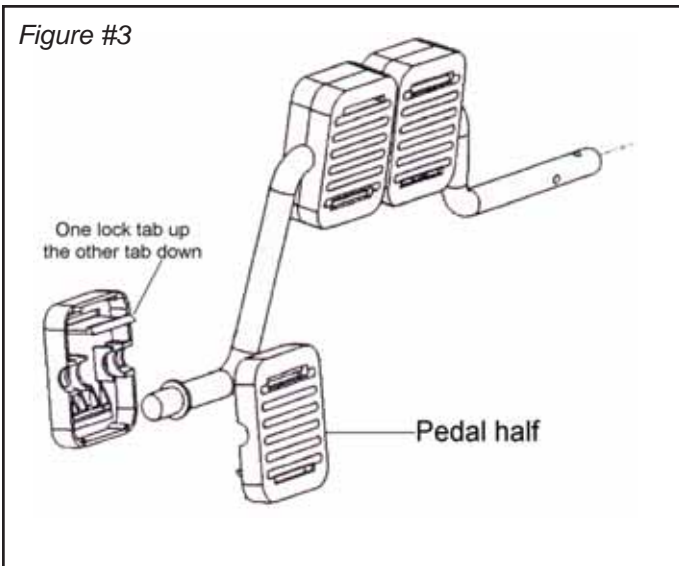



PROCEDURE D) UNIVERSAL STEERING ROD REPLACEMENT

►**Note: ONLY the universal rod requires the adjuster.**

- 1) Being able to lean the boat against a wall is helpful.
- 2) Remove the fastener that is holding the steering elbow in place.
- 3) Slide the steering elbow off the tiller steering handle.
- 4) Position the steering elbow so the flat edge is facing up. Push elbow onto rod following the U of the steering rod around until the steering elbow stops. See Figure 1.
- 5) Insert adjuster through the hole in rudder bracket. Place washer on top of rudder bracket side. Insert cotter pin in the hole of adjuster. Bend out tabs on cotter pin with vice grips or pliers. See Figure #2.
- 6) Slide steering rod through adjuster hole with hooked end of steering rod facing up toward front of boat.
- 7) The steering rod must be on an angle from front to back. If straight, the boat will go in circles.
- 8) The curve of tiller steering handle must be pointing toward the bow of the boat. Holding the tiller steering handle in place slide steering elbow back on to tiller steering handle. If the holes in the steering elbow and steering handle do not line up, use a #10 (.192), drill bit and re-drill the holes. Re-attach the steering elbow to the handle.
- 11) Be sure rudder and tiller steering handle are in the straight position. Insert adjuster bolt into the bottom of adjuster and tighten until snug with a 1/2" wrench.
- 12) If necessary, cut steering rod 2" out from adjuster with hacksaw.
- 13) When assembly is completed, it should look like Figure #3.

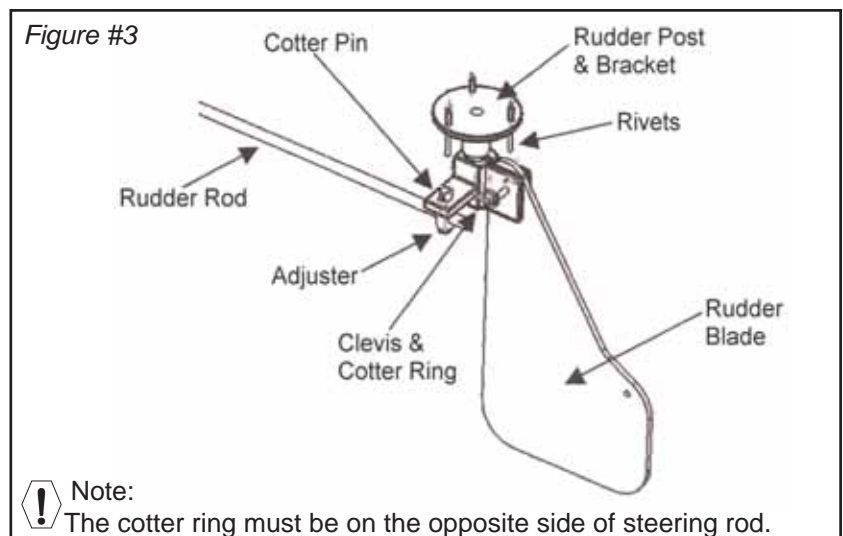
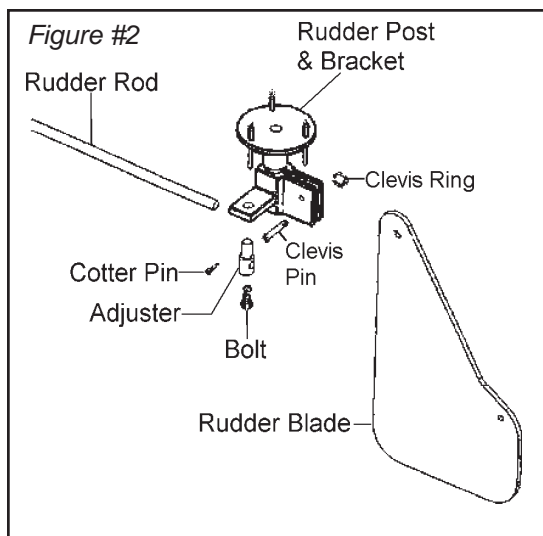
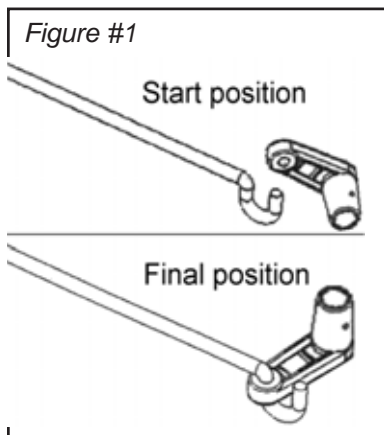



PROCEDURE E) RUDDER BRACKET / POST REPLACEMENT (1998 - CURRENT)

- 1) Drill out rivets that hold the rudder post to boat. See Figure #9.
- 2) Set new rudder post in place.
- 3) Using a hand rivet gun install three explosion rivets into the existing holes.
- 4) Assemble steering rod on rudder bracket before attaching rudder bracket to rudder post:
 For original rudder rod - start at the open end and go around first bend of the rudder rod until it stops.
 For universal rod - see earlier pages and Figure #8 for placement of adjuster.
 Important: the part of the bracket that holds the rudder must be facing rear of boat. See Figure #10
- 5) Snap rudder bracket on rudder post.
- 6) Insert rudder into the rudder bracket.
- 7) Insert clevis pin through the top hole of the rudder so it hangs with the straight side toward the front of the boat.
- 8) Secure with circle cotter pin.
 ▶Note: The cotter ring must be on the opposite side of steering rod.

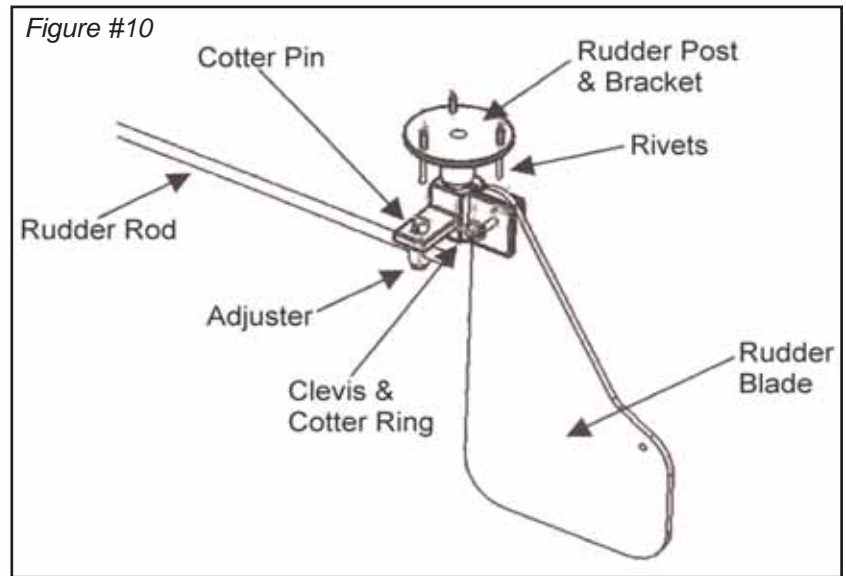
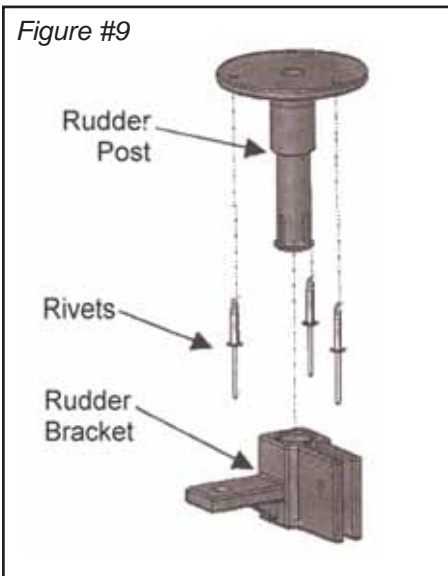

PROCEDURE F) RUDDER REPLACEMENT

- 1) Remove the nut and bolt or clevis and circle cotter pin that is holding the rudder in place
- 2) Insert new rudder into the rudder bracket. See Figure 8.
- 3) Insert clevis pin through the top hole of the rudder so it hangs with the straight side toward the front of the boat.
- 4) Secure with circle cotter pin. Important Note: the circle cotter pin must be on the opposite side of steering rod.



PROCEDURE G) STEERING BUSHING REPLACEMENT

- 1) Remove clevis and circle cotter pin from steering arm.
- 2) Remove steering elbow from steering handle.
- 3) Remove steering handle from deck side of boat.
- 4) Insert large screwdriver in top bushing hole on the deck side and pull back hard to break female and male bushing halves apart. **Do not use steering handle as tool to pry apart.**
- 5) Remove top and bottom bushings.
- 6) Insert male bushing on topside of boat.
- 7) Make sure gasket is on the female bushing.
- 8) Insert female bushing through hole on bottom side of boat. Support with block of wood or concrete block. Hit male bushing on topside of boat until 1/2 way down. Line up notch on the bushing with notch on boat. You will have to cut a notch out of your boat if you don't have one. Hit again until you can't turn bottom female bushing.
- 9) Replace steering handle. The curve of steering handle must be pointing toward the bow of the boat.
- 10) Be sure rudder and steering handle are in the straight position. Holding the steering handle in place slide steering elbow back on to steering handle. Give a slight tap with a small hammer if necessary.
- 11) Line up hole on steering handle and steering elbow.
- 12) Replace clevis and circle cotter pin.



PROCEDURE H) TILLER STEERING HANDLE REPLACEMENT

- 1) Remove clevis and circle cotter pin from steering elbow.
- 2) Remove steering elbow from tiller steering handle.
- 3) Remove tiller steering handle from deck side of boat.
- 4) Insert new tiller steering handle through bushing from deck side of boat. See Figure #1.
- 5) Be sure rudder and tiller steering handle are in the straight position. The curve of tiller steering handle must be pointing toward the bow of the boat. Holding the tiller steering handle in place slide steering arm back on to tiller steering handle. Give a slight tap with a small hammer if necessary.
- 6) Drill hole into steering elbow and tiller steering handle 1 1/2" from bottom of boat.
 The hole position is not critical as long as it is above the arm of the steering elbow. See Figure #1 and #2.
- 7) Replace clevis and circle cotter pin.

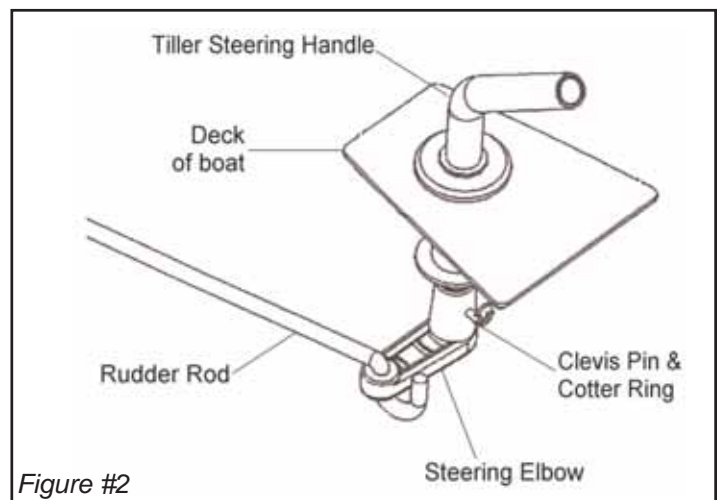
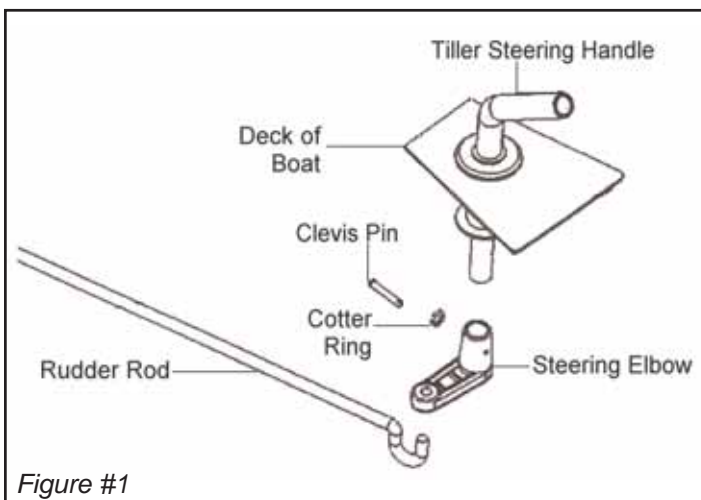

PROCEDURE I) STEERING ELBOW REPLACEMENT

- 1) Remove clevis and circle cotter pin from steering elbow.
- 2) Remove steering elbow from tiller steering handle.
- 3) Remove steering rod from steering elbow.
- 4) Position the steering elbow so the flat edge is facing up.
- 5) Follow the U of the steering rod around until the steering elbow stops. See Figure #2.
- 6) The steering rod must be on an angle from front to back. If straight, the boat will go in circles.
- 7) Be sure rudder and tiller steering handle are in the straight position. The curve of tiller steering handle must be pointing toward the bow of the boat. Holding the tiller steering handle in place slide steering arm back on to tiller steering handle. Give a slight tap with a small hammer if necessary.
- 8) Drill hole into steering elbow and tiller steering handle 1 1/2" from bottom of boat.
 The hole position is not critical as long as it is above the arm of the steering elbow. See Figure #1 and #2.
- 9) Replace clevis and circle cotter pin.



PROCEDURE J) CANOPY STRAP REPLACEMENT GUIDE

These instructions apply to SKU 4876061 only. This canopy strap replacement kit will work on either the 2 bow or 3 bow canopy. This kit contains asymmetrical straps as shown in version A.

The two primary variations in canopy design are shown below. Please follow the directions for your particular version. The straps should be placed so that when the canopy is up on the boat, the straps are pulling outboard. Be sure the strap is not pulling against the head of the rivet, this would cause the strap to eventually tear off from the rivet.

To attach the new straps, pop rivet the strap to the pole and wind the strap over the pole. See Figure 1.

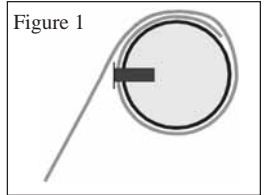

Version A) Asymmetrical Straps

1. Carefully drill out the rivets holding the old straps to the canopy poles.
2. The new straps will attach using the original holes in the canopy poles.
2. The straps should be placed so that when the canopy is up on the boat, the straps are pulling outboard. Be sure the strap is not pulling against the head of the rivet, this would cause the strap to eventually tear off from the rivet. To attach the new straps, pop rivet the strap to the pole and wind the strap over the pole. See Figure 1.



Version B) Equi-Length Straps

*Conversion to asymmetrical straps does not require moving the pad eyes.

1. Remove the old straps by carefully cutting the strap loop around the canopy poles.
2. Begin with the longer front strap. Drill an 1/8" hole in the pole, centered up in the opening of the canopy fabric. Attach the strap as shown in Fig. 1.
3. For the shorter rear straps, measure and mark a spot on the canopy pole approximately 18" from bottom of the deck hinge and drill an 1/8" hole. Repeat for other side. See Figure 2.
4. Attach shorter rear straps as as shown in Fig. 1.

